

ConSpare

Make it better.

DataSheet

CDX Mixer Venting Filter

CDX mixer venting filters improve both the safety of the plant and efficiency of the concrete production process. During the batching cycle the purpose-built filter creates negative pressure within the mixing pan. This pressurised environment is highly effective at controlling airborne dust produced during the loading of dry materials. The result is a significant reduction in dust emissions from the mixer, keeping the mixer platform cleaner, safer and protecting site staff. The reverse jet conical cartridge system is also highly efficient, with the filtered material being returned directly back to the mixer for each batch, resulting in minimum waste.



Keep mixer platforms clean and safe. Protect staff

Control dust emission during the batching cycle

Quiet operation and minimal running costs

Compact design and simple to install

Highly efficient conical cartridge

Suitable for mixers 500 litres - 4500 litres

CDX filters are installed throughout the UK on pan, planetary and twinshaft mixers ranging in capacities from 500 litres to 4500 litres. The system utilises innovative conical cartridges which enable the filter to offer superior performance combined with lower operating costs, simpler maintenance and better reliability.



CDX 12.5 - Single cartridge
Compact footprint for tight spaces



CDX 25 - Double cartridge
For larger mixer capacities



Quick and safe cartridge access
Reverse jet cleaning extends life

Visit - www.conspare.com | Call +44 (0)1773 860796 | Email - sales@conspare.com

ConSpare Limited Registered in England No. 10373473
Castlewood Business Park, Farmwell Lane, Sutton-in-Ashfield, Nottinghamshire. NG17 1BX.
We reserve the right to modify or withdraw specifications or products without notice or obligation.



CDX models and installation

CDX mixer venting filters are available in two sizes. CDX 12.5 is a single conical cartridge unit, suitable for mixers with capacities 500 litres - 3000 litres. CDX 25 features two conical cartridges and is suitable for larger mixers with capacities 3000 litres - 4500 litres.

Installing CDX is quick and simple. The design of CDX is particularly compact, and the minimal footprint allows for installation in tight spaces. Units are positioned directly above the mixer, and mounted to steelwork above the mixer itself or on to a mezzanine level above. The unit comes complete with weldable mixer connection spigot.

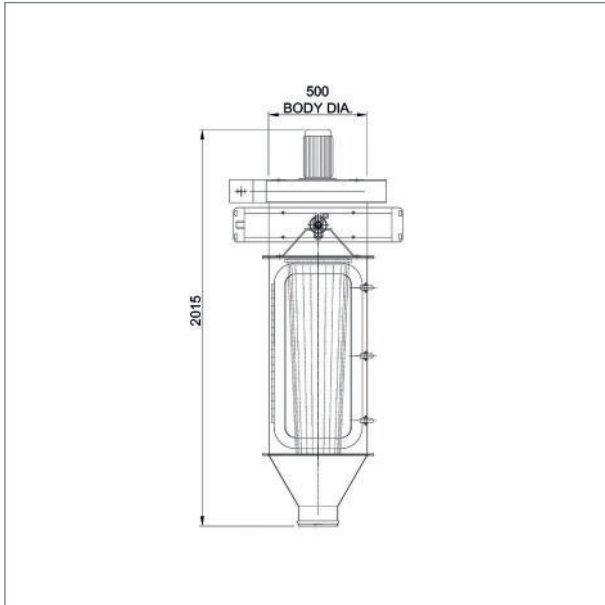

CDX 12.5

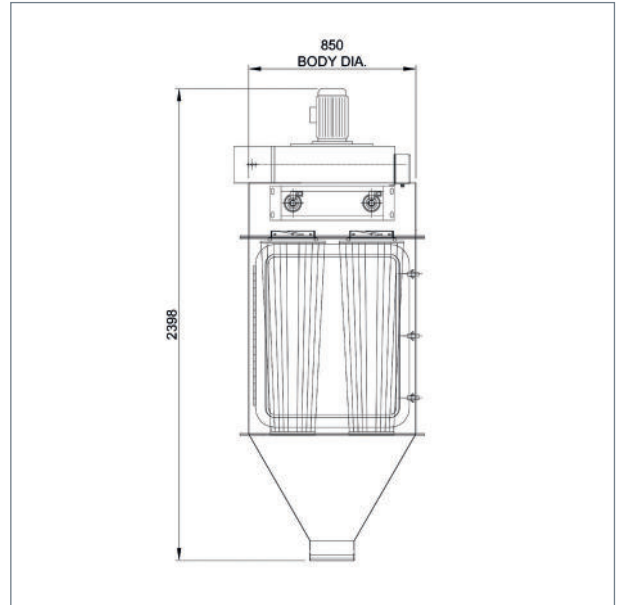

CDX 25

Upgrade the mixing process



High quality mixing
Teka pan, planetary, turbine & twinshaft

Teka



Keeping mixers clean
Walter high pressure cleaning systems

WALTER
next level cleaning

Visit - www.conspare.com | Call +44 (0)1773 860796 | Email - sales@conspare.com

ConSpare Limited Registered in England No. 10373473
Castlewood Business Park, Farmwell Lane, Sutton-in-Ashfield, Nottinghamshire. NG17 1BX.
We reserve the right to modify or withdraw specifications or products without notice or obligation.

