

ConSpare

Make it better.

DataSheet

SafePoint Failsafe Rotary Switch

In our capacity as sole distributor for Monitor Technologies we supply a comprehensive range of level switches offering site proven reliability at highly competitive prices.

The SafePoint rotary paddle level switch is a new generation switch incorporating microcontroller based continuous self monitoring diagnostics. The unique 'failsafe' design makes a significant contribution in helping to protect site personnel, silos, venting filters and the environment. The SafePoint incorporates industry first patented magnetic sensing technology ensuring reliability wherever critical continuous operation must be ensured. Independent SPDT relays for material sense and fault outputs allow for flexible control wiring.



Unique 'failsafe' design

Self monitoring diagnostics

Industry first magnetic sensing

Independent output relays

Rugged user friendly housing

LED operation indicator

ATEX and high temp options

Monitor level switches generate an alarm signal once material in storage vessels reaches a predetermined high, low or intermediate level. They are suitable for use in silos, hoppers and bins containing free-flowing granular materials such as cement, cement substitute, sand and aggregates.

A comprehensive range of interchangeable paddle assemblies is available from stock helping to increase versatility. Extension rods with threaded and pinned connectors for secure fixing are available in a variety of lengths to suit application requirements. For full specification please see Bulletin 253 on our website.



Sole distributor for
Monitor Technologies

Visit - www.conspare.com | Call +44 (0)1773 860796 | Email - sales@conspare.com

ConSpare Limited Registered in England No. 10373473
Castlewood Business Park, Farmwell Lane, Sutton-in-Ashfield, Nottinghamshire. NG17 1BX.
We reserve the right to modify or withdraw specifications or products without notice or obligation.



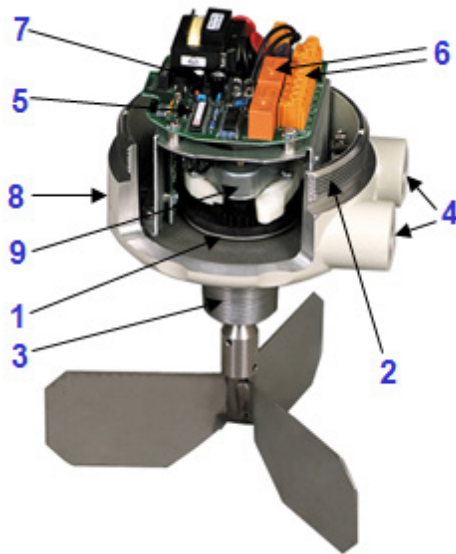

1. Magnetic sensing technology ensures reliable operation even in dusty environments.
2. Twist on/off cover for convenient and easy access. No bolts to lose or hold.
3. 1-1/4" NPT or 1-1/2" BSPT process connections.
4. Two conduit connections provides easy wiring access.
5. Microcontroller-based electronics ensures consistent and reliable operation.
6. Independent SPDT relays for materials sense and fault out-puts provides for flexible control wiring.
7. Indicating light (ordinary locations only) provides local visual indication of operating status.
8. Cast aluminium housing with rugged powder coat finish suitable for a wide range of applications.
9. Motor shuts off when paddle is impeded. Significantly extends motor life and reduces operating costs.

Visit - www.conspare.com | Call +44 (0)1773 860796 | Email - sales@conspare.com

ConSpare Limited Registered in England No. 10373473
Castlewood Business Park, Farmwell Lane, Sutton-in-Ashfield, Nottinghamshire. NG17 1BX.
We reserve the right to modify or withdraw specifications or products without notice or obligation.

