

Side Sealing System Type S

Clean Transferpoint Technology

less
spillage,
more
performance



SealTek provides a perfect seal for conveyor belt transfer points. SealTek contributes to a clean, safe and healthy work environment. SealTek's design is the result of over 60 years' experience in optimizing conveyor belt systems.

Feed and transfer points of conveyor belt systems are a source of material spillage and fugitive dust. The disadvantages are evident:

- costly material spillage
- damage to health and environment
- increased risk of accidents and unsafe situations
- unplanned and costly downtime
- additional cleaning costs
- increased wear

By installing the SealTek side and rear sealing system, optimal sealing of your transfer point is guaranteed, even under the harshest conditions.

Collectively, the blocks form a continuous seal, but can be individually adjusted or replaced easily and quickly. The unique and patented sealing system is sustainable, thanks to its extremely long service life and the low amount of residual waste when replacing a sealing block.

Why SealTek

- minimal contamination and fugitive dust nuisance at conveyor belt transfer points
- easy to assemble and maintain
- prevents spillage of costly material
- contributes to a clean and safe work environment
- little residual waste
- very long service life
- minimal installation height required
- low maintenance

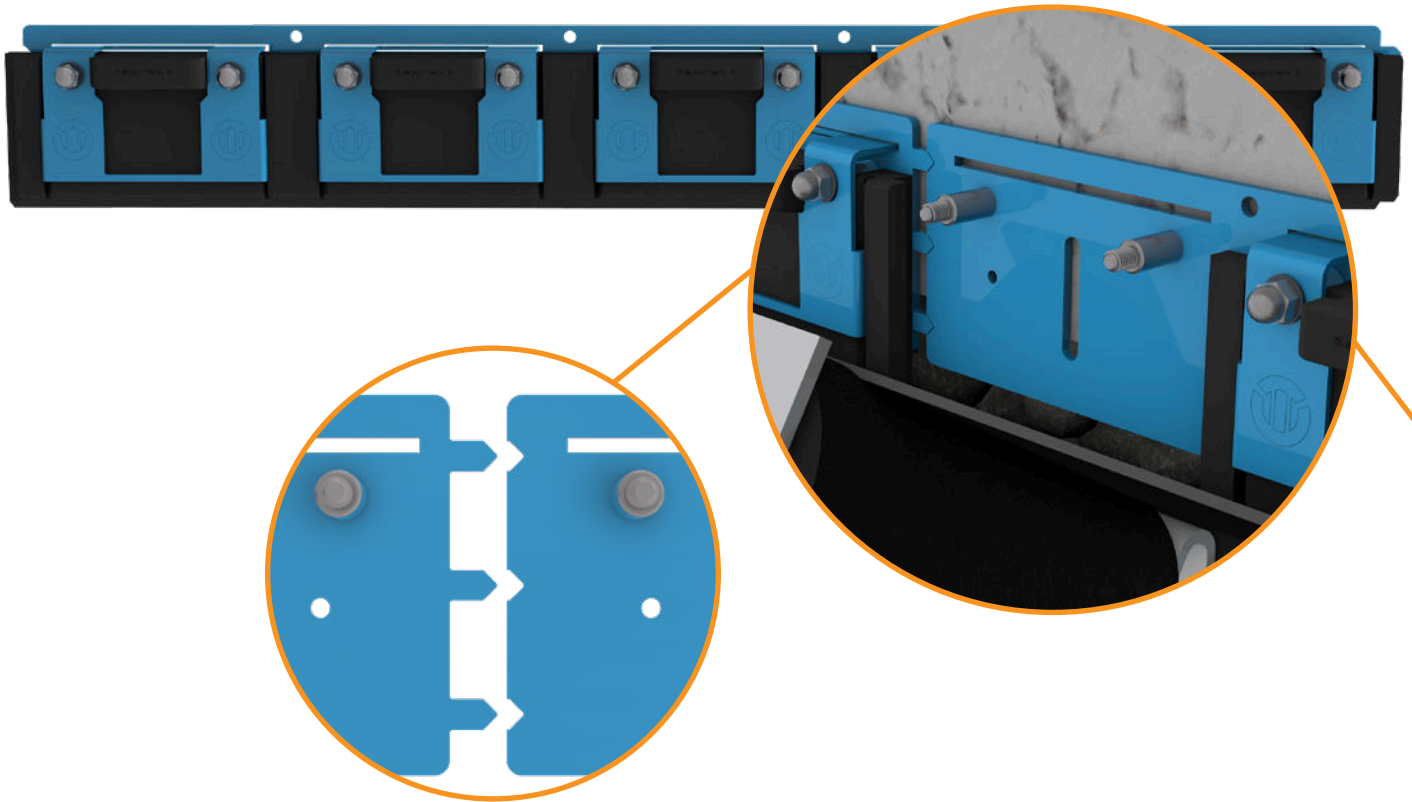

Backing Plate

The 5 mm thick wear-resistant backing plate is attached to the side wall of the feed point either by welding or fasteners. The edge of each plate interlocks with the next plate, making assembly much easier.

The backing plate also acts as a wear plate and protects the sealing blocks from excessive lateral material pressure.

SealTek-S

Sealing blocks

The SealTek sealing system type S consists of one metre length backing plates. Five sealing blocks are mounted on a single plate using an interlocking method. As a result, the blocks form one continuous seal.

The robust sealing blocks are only 115 mm high and 25 mm thick. They are manufactured from wear-resistant elastic rubber, which is softer than the conveyor belt. This prevents wear, cuts and/or damage to the belt.

Each sealing block can be individually adjusted downwards by 60 mm. Only then does a block need to be replaced. This has two major advantages: the service life is extremely long, and the amount of residual waste is minimal.



Clamping Brackets

Stainless steel serrated clamping brackets guide the sealing blocks and keep the blocks from rotating or being pushed away. Even when the block is virtually worn out. The serrated clamp allows the block to be adjusted downwards, but not pushed up.

➤ SealTek-R

In practice, the rear connection of a transfer point to the side seal is often insufficient. This becomes a source of fugitive dust, contamination and material spillage. SealTek-R fits seamlessly to the blocks on the sides and thus perfectly seals the rear of the transfer point.

The sealing module consists of a loose mounting strip, a rubber sealing block, and a serrated clamping bracket. The modules are fixed side by side onto the back wall. The mounting strip not only acts to hold the sealing block, but also serves as a guide for the block.

The sealing blocks and clamping brackets can be adjusted to any trough angle. Thanks to its modular design, SealTek-R fits on any rear wall.

SealTek-R fits seamlessly to the blocks on the sides (SealTek-S). This seals the transfer point perfectly.

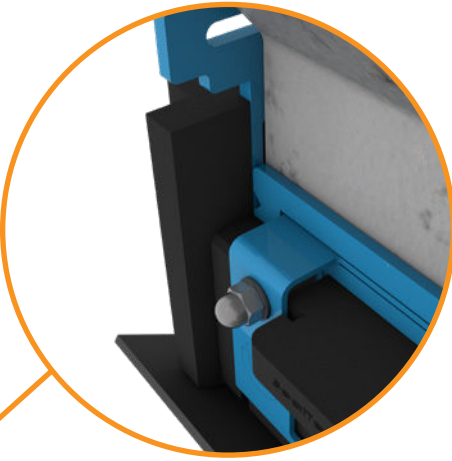

SealTek-R sealing module

Properties

- interlocking construction provides perfect continuous sealing
- seamless connection between side and rear seal
- easy to adjust
- blocks can be replaced quickly and individually
- special rubber compound protects the conveyor belt
- quick return on investment
- sustainable, thanks to long service life and low amount of residual waste
- customizable to any conveyor belt

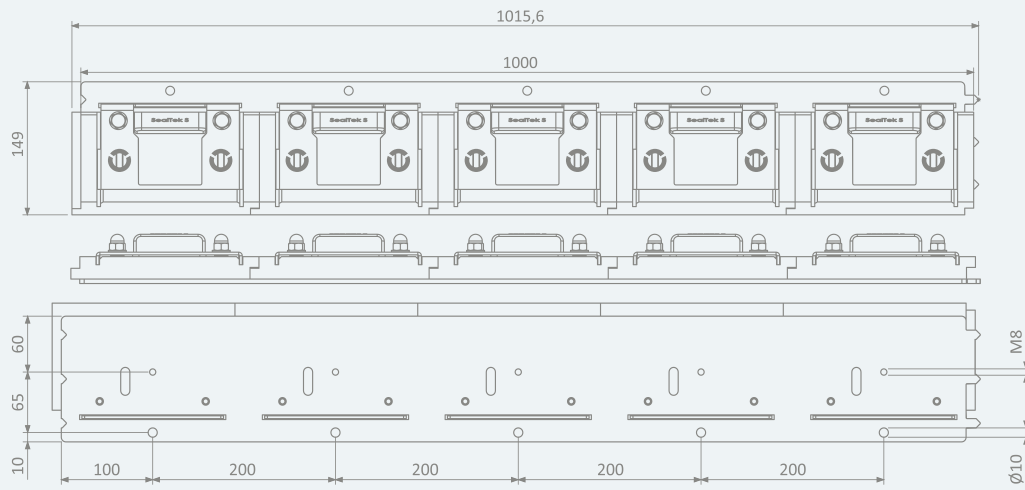

Product Dimensions and Size Chart

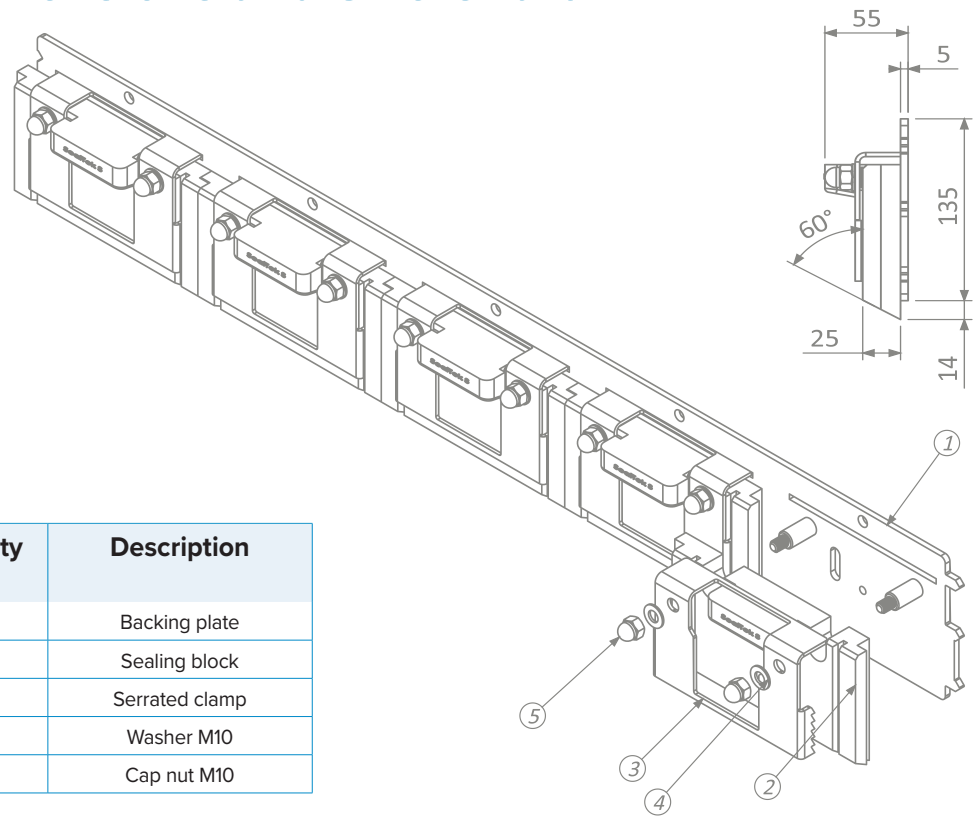

Pos.	Quantity	Description
1	1	Backing plate
2	5	Sealing block
3	5	Serrated clamp
4	10	Washer M10
5	10	Cap nut M10

Seamless connection

The system is available in two versions: one for the sides (type S) and one for the rear (type R). The seal on the rear wall (SealTek-R) connects seamlessly to the side seals of the system (SealTek-S).

Members TBK Group:

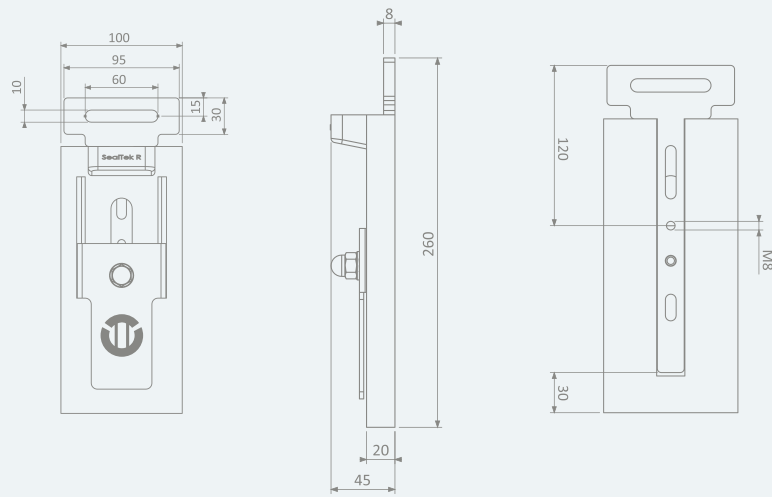

Product Dimensions and Size Chart

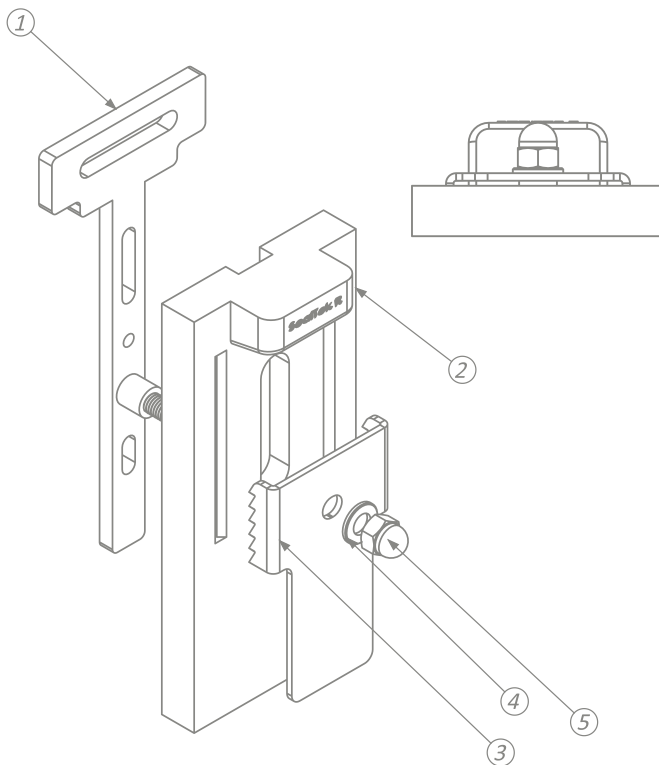

Pos.	Quantity	Description
1	1	Backing plate
2	1	Sealing block
3	1	Serrated clamp
4	1	Washer M10
5	1	Cap nut M10



Adjusting and replacing

SealTek blocks can be individually adjusted and replaced. Thanks to its ingenious design, the blocks are easily adjusted downward using a light hammer knock, without the need to loosen the nuts. The interlocking method of assembly also makes replacing an individual sealing block very easy.



Side Sealing System Type R

less
spillage,
more
performance

Clean Transferpoint Technology