

Tool Release (TR) Connectors

The BFM® TR (Tool Release) Connector has been developed for applications where the connector is mounted very close to equipment that is rotating or spinning very fast, providing additional safety for production and maintenance staff. The Snap Ring of the BFM® TR connector is manufactured to have a firmer fit than an a standard connector which also makes it ideal for negative pressure (vacuum) applications.

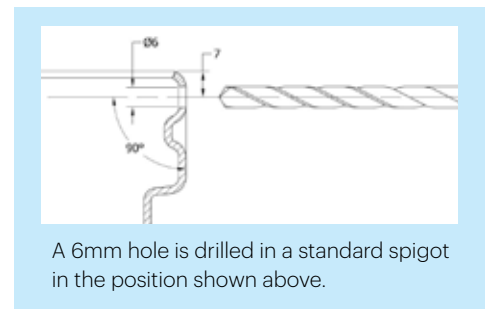

A 6mm hole is drilled in a standard spigot in the position shown above.

Once a BFM® TR connector is fitted, it is virtually impossible to remove it manually. It is, however, straightforward to remove using a TR Release Tool, which is simply inserted into a 6mm hole in the side of both the upper and lower spigots.

It is important to note that the BFM® TR connector fits very firmly in place and that caution must be used when inserting and removing the connectors.

Please refer to the installation instructions on the following page.



The BFM® TR (tool release) Seeflex O40E/O20E/O60ES fittings have a white embossed identifier stamp to make them easy to differentiate from our standard fittings. NB: O40AS TR connectors will still have an grey 'O40AS' stamp on the front, but the batch label on all connectors will have a product description which will identify the connector as a 'TR'.

Smiley Face Tool Release Option



For an added level of security, the BFM® 'Smiley Face' TR option has a unique 'smiley' shaped hole that is punched into the spigot (instead of the standard 6mm drilled hole).

This stops the use of any 'makeshift' Tool Release tools, such as screwdrivers, and will only allow the specially shaped 'Smiley Face' TR tool to be used.

The 'Smiley Face' tool can be kept securely to ensure only authorised use is possible.

A special Smiley Face pneumatic punch is used to make the special Smiley Face holes in minutes.

CAUTION:

Although the firmer TR band is a significant deterrent to manual removal, if an individual is determined enough, **it may still be possible.**



Another very popular way of ensuring safety while using the BFM® fitting near rotating equipment is to use **BFM®'s Pneumatic Monitoring System.**

For more information, please see the 'BFM® Guidelines: Pneumatic Monitoring System Installation'.

Tool Release (TR) Connectors

Installation:



01. Ensure the BFM® spigot is clean and dry.



02. Seat the back of the connector into the BFM® spigot and release. The cuff will snap into the spigot (ensure to keep fingers clear).



03. Snap into the second spigot, ensuring that the welded seam of the connector is straight and that points A and B are directly in line.

IMPORTANT: POSITION CUFF WELDS AWAY FROM THE TR TOOL INSERTION HOLE

All Seeflex range TR connectors are made so that the weld in the cuff is positioned away from the embossed ' label on the front of the connector.

To reduce the chance of the TR tool being inserted directly on the weld in the snap-band (which is naturally the weakest point), always ensure you position the front ' label directly above the TR insertion hole on the spigot.

For TR connectors made of other materials, ensure the batch label (on the inside of the connector cuff, directly over the welding point) is positioned at least 25mm away from the TR hole.



Removal:



01. Insert the removal tool in the opening of the hole and push towards the centre of the fitting.



02. Hold the seal of the connector and remove from the spigot.

CAUTION!

It is important when installing or removing the TR fitting to keep your fingers clear of the seal as it snaps into place with force.

Your spigots are now ready for a new connector.

BFM® Global makes no warranty of any kind, expressed or implied, except that goods sold shall be of merchantable quality, free of manufacturing defect, and the buyer assumes all risk and liability resulting from the use of the goods, whether used singly or in combination with other products.